



PCI TOP C011 Single

PCI TOP, built-in application

Product description

- For quartz and ceramic lamps
- Also for mobile luminaires with connectors
- Pulse packets for increased ignition energy (pulseCONTROL technology)
- Flicker-free light
- Colour stability thanks to constant power
- Low power loss
- Low weight
- No acoustic resonance
- Safety shutdown if a lamp is faulty or missing
- Greatly reduced reignition time
- Hardly any EMC interference in the ignition phase
- Automatic shutdown on overheating
- Casing: PBT-RG151 acc. to UL94-V0, white; steel base plate
- Push-in terminals up to 1.5 mm²

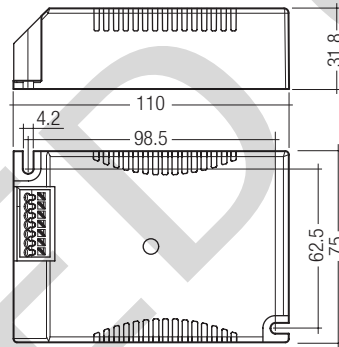

Technical data

Mains voltage range	220 – 240 V
AC voltage range	198 – 254 V
DC voltage range	176 – 280 V
Mains frequency	0 / 50 / 60 Hz
Max. ignition voltage	5 kVp
Operating frequency	140 Hz
Type of protection	IP20

Ordering data

Type	Article number	Packaging, carton	Packaging, low volume	Packaging, high volume	Weight per pc.
For luminaires with 1 lamp					
PCI 35 TOP C011	28000014	20 pc(s).	440 pc(s).	2,200 pc(s).	0.206 kg
PCI 50 TOP C011	28000015	20 pc(s).	440 pc(s).	2,200 pc(s).	0.206 kg
PCI 70 TOP C011	28000016	20 pc(s).	440 pc(s).	2,200 pc(s).	0.209 kg



Standards, page 2

Wiring diagrams and installation examples, page 2

Specific technical data

Lamp wattage	Lamp type	Type	Article number	Dimensions L x W x H	Lamp wattage	Circuit power ^①	EEL	Efficiency	Current at 50 Hz 230 V	λ at 50 Hz 230 V	Max. cable length to lamp	tc point max.	Ambient temperature ta	tc/ta for ≥ 50,000 h
For luminaires with 1 lamp														
1 x 35 W	HI	PCI 35 TOP C011	28000014	110 x 75 x 32 mm	39 W	44.0 W	A2	> 87 %	0.20 A	0.97	1.5 m / 120 pF	80 °C	-20 ... +60 °C	80/60 °C
1 x 50 W	HI	PCI 50 TOP C011	28000015	110 x 75 x 32 mm	50 W	55.0 W	A2	> 89 %	0.25 A	0.96	1.5 m / 120 pF	75 °C	-20 ... +55 °C	75/55 °C
1 x 70 W	HI	PCI 70 TOP C011	28000016	110 x 75 x 32 mm	73 W	80.5 W	A2	> 90 %	0.35 A	0.97	1.5 m / 120 pF	75 °C	-20 ... +50 °C	75/50 °C

① At ta = 25 °C.

Installation instructions

Wiring type and cross section

Stranded wire with ferrule or solid wire up to 1.5 mm² may be used for wiring. Strip 8.5–9.5 mm of insulation from the cables to ensure perfect operation of the push-in terminals. Use one wire for each terminal connector only.

wire preparation:
0.5 – 1.5 mm²

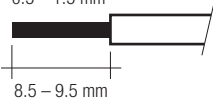

Note on wiring

The length of the lamp wires is limited by the value of cable capacitance. The maximum of 120 pF would enable connection of approximately 1.5 m of lamp wire.

To avoid the damage of the control gear, the wiring must be protected against short circuits to earth (sharp edged metal parts, metal cable clips, louver, etc.).

In class 1 luminaires it is necessary to earth the ballast and the luminaire via the earth terminal, in class 2 luminaires not.

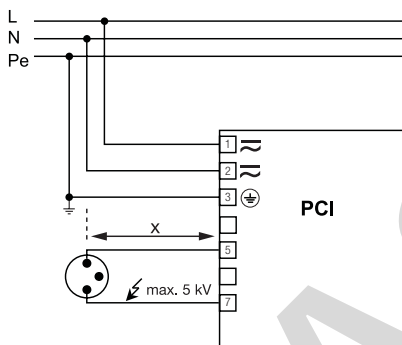

Circuit diagram PCI class 1 application

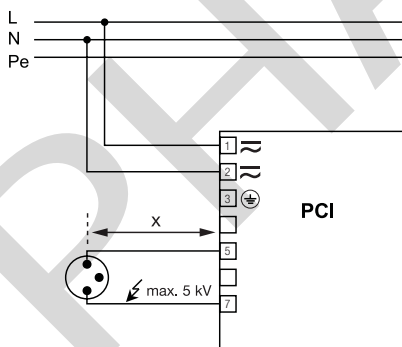

Circuit diagram PCI class 2 application

Mounting recommendation

Optimum heat transport can help improving the lifetime. Whenever possible keep the ballast away from hot parts.

To ensure optimum heat removal the ECG should be mounted on a metal plate (luminaire body). No insulators between the ECG and the the cooling surface (air, adhesive tape, etc.). Finally important remains the temperature measurement.

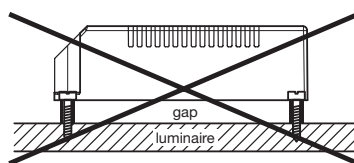

If several ballasts are installed in masts, boxes, etc., measures must be taken to avoid overheating of individual components.

Radio interference

- Do not cross mains and lamp cables.
- Do not lay mains cables together with lamp cables (ideally they should be 5–10 cm apart).
- Do not lead mains cables too closely along the electronic ballast.
- Twist lamp cables.
- Increase the distance between lamp cables and earthed metal surfaces.
- Keep the mains cable in the luminaire short.
- Parallel runs (x) of mains and lamp cables must be kept as short as possible.

Important advise

When a lamp is changed (at the end of its life), if a lamp is missing or after overtemperature shutdown the mains voltage of the ECG must be disconnected.

Warning – starting voltage up to max. 5 kV!

Not suitable for use with lamps with integral ignitors. A list of released lamps for the save operation with PCI can be found on www.tridonic.com → Technical Data → Lamp matrix → Lamp matrix for HID

Safety switch off

End of life of the lamps

At the end of their useful life, lamps often cycle on/ off. The PCI ballast recognises this condition and switches off the lamp, after three complete on/ off cycles and whilst the supply has been unswitched. Complete lamp switch off enables easy identification of a defective lamp in the application. After a change of the faulty lamp and an interruption of the mains supply (mains reset) the ballast will strike the lamp. When there is no lamp in circuit or a defective lamp is connected to the ballast, the ballast will switch off after apr. 25 minutes.

Overtemperature shutdown

The units shut down at Δt approx. +10 ... 20 °C compared with tc. A mains reset must be carried out so that the units switch on again.

Overload strength

320 V for 1 h, 280 V for 10 h

Standards

- EN 55015 (radio interference)
- IEC 61000-3-2 (mains harmonics)
- IEC 61347-2-12
- IEC 61547 (interference immunity)
- IEC 61167

Glow wire test acc. to EN60598-1

- 650 °C passed
- 850 °C passed
- 960 °C passed

Harmonic distortion in the mains supply

Type	THD at 230 V/50 Hz
PCI 35 TOP	< 10 %
PCI 50 TOP	< 10 %
PCI 70 TOP	< 10 %

Ballast lumen factor EN 60929 8.1

Type	AC/DC-BLF at U = 198–254 V, 25 °C
PCI 35 TOP	1.00
PCI 50 TOP	1.00
PCI 70 TOP	1.00

Loading of automatic circuit breakers

Automatic circuit breaker type	C10	C13	C16	C20	B10	B13	B16	B20
Installation Ø	1.5 mm ²	1.5 mm ²	1.5 mm ²	2.5 mm ²	1.5 mm ²	1.5 mm ²	1.5 mm ²	2.5 mm ²
PCI 35 TOP	28	40	44	58	14	20	22	29
PCI 50 TOP	18	28	30	36	9	14	15	18
PCI 70 TOP	18	28	30	36	9	14	15	18

Temperature range

The t_a temperature value is the basis for specifying the rated life.

The relationship between the t_c temperature and the t_a temperature depends on the design of the luminaire. If the measured t_c temperature is approximately 5 K under the t_c max. temperature the t_a temperature should be checked and, if necessary, measurements should be taken on the critical components (e.g. electrolytic capacitor).

Detailed information is available on request.

PCI TOP C011 is designed for an average life of 50,000 hours under rated conditions, with a failure probability of less than 10 %. This corresponds to an average failure rate of 0.25 % per 1,000 hours of operation.

The specified t_c temperature is the maximum permitted value (rated temperature according to EN 61347-1). Above this safety-related value the thermal cutout protects the device against damage.

The expected life-time values are shown in the following table. The t_c values are the relevant values here.

Storage conditions

Humidity: 5 % up to max. 85 %,
not condensed
(max. 56 days/year at 85 %)

Storage temperature: -40 °C up to max. +80 °C

The devices have to be within the specified temperature range (t_a) before they can be operated.

Expected life-time

Type	Lamp type	Lamp power	t_a	40 °C	45 °C	50 °C	55 °C	60 °C
PCI 35 W TOP	HI	1x35 W	t_c	60 °C	65 °C	70 °C	75 °C	80 °C
			Life-time	> 50,000 h	> 50,000 h	> 50,000 h	50,000 h	50,000 h
PCI 50 W TOP	HI	1x50 W	t_c	60 °C	65 °C	70 °C	75 °C	x
			Life-time	> 50,000 h	> 50,000 h	50,000 h	50,000 h	x
PCI 70 W TOP	HI	1x70 W	t_c	65 °C	70 °C	75 °C	x	x
			Life-time	> 50,000 h	50,000 h	50,000 h	x	x

x ... not permitted

Isolation and electric strength testing of luminaires

Electronic devices can be damaged by high voltage. This has to be considered during the routine testing of the luminaires in production.

According to IEC 60598-1 Annex Q (informative only!) or ENEC 303-Annex A, each luminaire should be submitted to an isolation test with 500 V_{DC} for 1 second. This test voltage should be connected between the interconnected phase and neutral terminals and the earth terminal.

The isolation resistance must be at least 2 MΩ.

As an alternative, IEC 60598-1 Annex Q describes a test of the electrical strength with 1500 V_{AC} (or 1.414 x 1500 V_{DC}). To avoid damage to the electronic devices this test must not be conducted.

Additional information

Additional technical information at
www.tridonic.com → Technical Data

Guarantee conditions at
www.tridonic.com → Services

No warranty if device was opened.