

EM powerLED PRO EZ-3, 4 W

Combined emergency lighting LED Driver 1 – 4 W

Product description

- Emergency lighting LED Driver with DALI interface and automatic test function
- For self-contained emergency lighting
- SELV for output voltage < 60 V DC
- Low profile casing (21 x 30 mm cross-section)
- 5-year guarantee

Properties

- Non maintained operation
- DALI interface for controlled testing and monitoring
- Constant current mode
- With either screw or clip fastening (clip-fix)
- 1, 2 or 3 h rated duration
- Selectable operating time (jumper)
- Output power limitation
- Two-colour status display LED
- Automatic restart after LED replacement
- Electronic multi-level charge system
- SELV (outputs powerLED, battery, status LED, test switch)
- Polarity reversal protection for battery
- Deep discharge protection
- Very low energy consumption from the battery after activation of the deep discharge protection
- Short-circuit-proof battery connection
- Addressing function, patented („EZ easy addressing“)
- Emergency lighting LEDs available

Tests:

- Status of the battery
- Status of the LED
- Charge condition
- Function test
- Duration test

Batteries

- High-temperature cells
- NiCd or NiMH batteries
- 4-year design life
- 1-year guarantee
- For battery compatibility refer to table „Battery selection“



Screw-fix

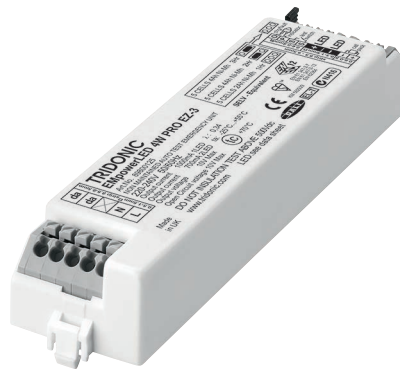

Clip-fix

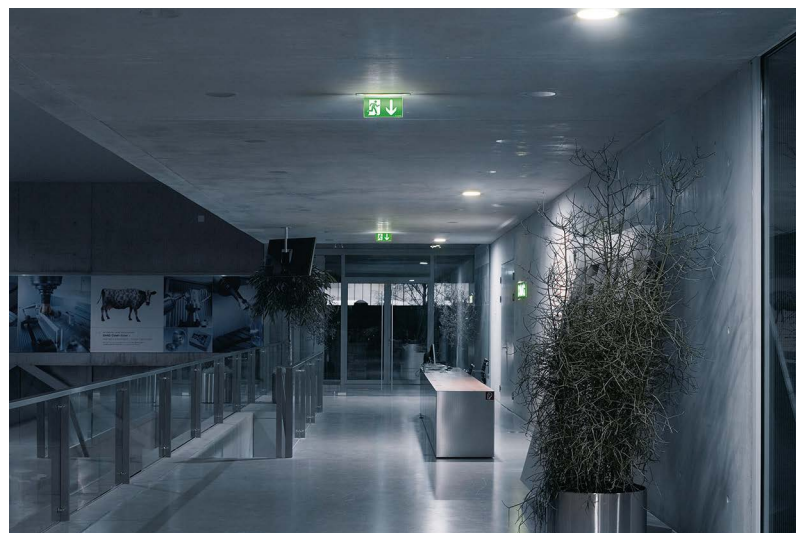

Batteries, page 5

Standards, page 6

Wiring diagrams and installation examples, page 9



EM powerLED PRO EZ-3, 4 W

Combined emergency lighting LED Driver 1 – 4 W

Technical data

Rated supply voltage	220 – 240 V
Mains frequency	50 / 60 Hz
Typ. λ (at 230 V, 50 Hz)	0.34
Forward voltage range LED module (1 x LED)	2.8 – 3.4 V
Forward voltage range LED module (2 x LED)	5.6 – 6.8 V
Max. open circuit voltage	10 V
LED current in emergency operation (1 x LED)	1.000 mA
LED current in emergency operation (2 x LED)	700 mA
Typ. output power (1 x LED)	3.4 W
Typ. output power (2 x LED)	4.5 W
Time to light	0.23 s from detection of emergency event
Overvoltage protection	320 V (for 1 h)
Battery discharge current	See page 5
Max. casing temperature t_c	70 °C
Ambient temperature t_a	-25 ... +45 °C
Mains voltage changeover threshold	according to EN 60598-2-22
Ingress protection	IP20

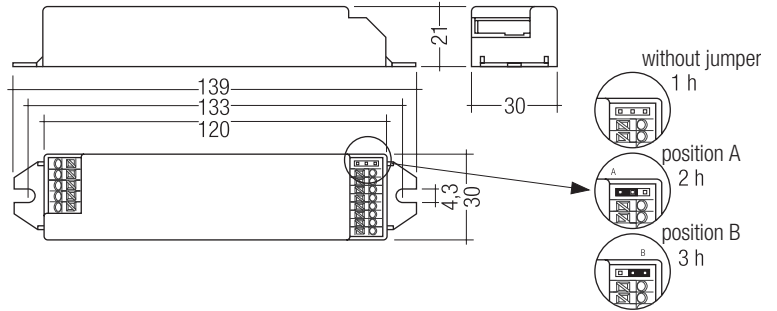

Screw-fix

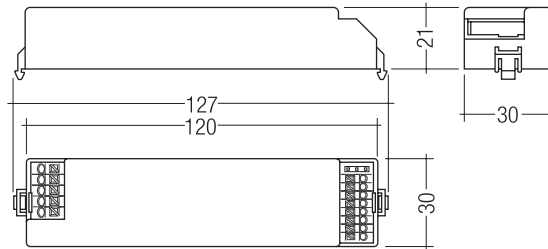

Clip-fix

Ordering data

Type [®]	Article number	Packaging, carton	Packaging, pallet	Weight per pc.	Max. number of LED	Power
Screw fastening version						
EM powerLED 4 W PRO EZ-3	89800126	25 pc(s).	1,200 pc(s).	0.068 kg	2	4 W
EM powerLED 4W PRO EZ-3 NiMH	89800446	25 pc(s).	1,200 pc(s).	0.068 kg	2	4 W

Specific technical data

Type [®]	Rated duration	Mains current in charging operation			Mains power in charging operation		
		Initial charge	Fast recharge	Trickle charge [®]	Initial charge	Fast recharge	Trickle charge [®]
EM powerLED 4 W PRO EZ-3	1 h	21.0 mA	27.5 mA	15.2 mA	2.0 W	3.0 W	1.2 W
EM powerLED 4 W PRO EZ-3	2 h	27.5 mA	32.4 mA	21.0 mA	3.0 W	3.7 W	2.0 W
EM powerLED 4 W PRO EZ-3	3 h	27.5 mA	32.4 mA	21.0 mA	3.0 W	3.7 W	2.0 W
EM powerLED 4 W PRO EZ-3 NiMH	1 h	19.0 mA	24.0 mA	13.0 mA	1.7 W	2.4 W	1.0 W
EM powerLED 4 W PRO EZ-3 NiMH	2 h	30.0 mA	32.0 mA	13.0 mA	3.1 W	3.3 W	1.1 W
EM powerLED 4 W PRO EZ-3 NiMH	3 h	30.0 mA	32.0 mA	13.0 mA	3.1 W	3.3 W	1.1 W

[®] For EM powerLED 4 W PRO EZ-3 NiMH: average over 20 min. (4 min. charge / 16 min. off)

[®] EM = Emergency

Test switch EM2

Product description

- For connection to the emergency lighting unit
- For checking the device function



Ordering data

Type	Article number	Packaging, bag	Packaging, carton	Weight per pc.
Test switch EM 2	89805277	25 pc(s).	600 pc(s).	0.011 kg

Status indication bi-colour LED

Product description

- Two-colour status display LED
- Green: system OK, red: fault



Ordering data

Type	Article number	Packaging, bag	Packaging, carton	Weight per pc.
LED EM bi-colour	89899720	25 pc(s).	200 pc(s).	0.017 kg
LED EM bi-colour, high brightness	89899753	25 pc(s).	800 pc(s).	0.013 kg

Battery selection

EM powerLED 4W PRO EZ-3, 1 / 2 / 3 h

		Type	EM powerLED 4W PRO EZ-3		EM powerLED 4W PRO EZ-3 NiMH	
		Article no.	89800126		89800446	
		Cells	5 cells		5 cells	
		Duration	1 h	2 / 3 h	1 h	2 / 3 h
Technology and capacity	Design	Number of cells	Type	Article no.	Assignable batteries	
NiCd 4 Ah	stick	1 x 5	Accu-NiCd 5A 55	28002774	•	
D cells	stick + stick	3 + 2	Accu-NiCd 5C 55	89800090	•	
NiMH 2,2 Ah	stick	1 x 5	Accu-NiMH 5A	28002090	•	•
Cs cells	side by side	5 x 1	Accu-NiMH 5B	28002093	•	•
NiMH 4 Ah LA cells	stick + stick	2 + 3	Accu-NiMH 4Ah 5C CON	89800439		•

Battery charge / discharge data

EM powerLED 4W PRO EZ-3, 1 / 2 / 3 h

		Type	EM powerLED 4W PRO EZ-3		EM powerLED 4W PRO EZ-3 NiMH		
		Article no.	89800126		89800446		
		Cells	5 cells		5 cells		
		Duration	1 h	2 / 3 h	1 h	2 / 3 h	
Battery charge time	Initial charge	20 h					
	Fast recharge	10 h	15 h	10 h	15 h		
	Trickle charge	continuously					
Charge current	Initial charge	130 mA	250 mA	130 mA	300 mA		
	Fast recharge	250 mA	330 mA	210 mA	330 mA		
	Trickle charge	60 mA	130 mA	127 mA / 4 min. 0 mA / 16 min.	201 mA / 4 min. 0 mA / 16 min.		
Discharge current		1,100 mA	1,100 mA	1,100 mA	1,100 mA		

Standards

- EN 61347-2-7
- EN 61347-2-13
- EN 62384
- EN 55015
- EN 61000-3-2
- EN 61000-3-3
- EN 61547
- EN 60068-2-64
- EN 60068-2-29
- EN 60068-2-30
- EN 62386 (according to DALI standard V1)
- according to EN 50172
- according to EN 60598-2-22
- according to EN 62034

Technical data batteries

Accu-NiCd

4.2 / 4.5 Ah

Battery voltage/cell	1.2 V
Cell type	D
Case temperature range to ensure 4 years design life	+5 °C to +55 °C
Max. short term temperature (reduced life-time)	70 °C
Max. number discharge cycles	4 cycles per year plus 4 cycles during comissioning
Max. storage time	6 months

Accu-NiMH

2.2 Ah

Battery voltage/cell	1.2 V
Cell type	Cs
Case temperature range to ensure 4 years design life	+5 °C to +50 °C
When used with EM powerLED 4W PRO EZ-3	+5 °C to +55 °C
When used with EM powerLED 4W PRO EZ-3 NiMH	70 °C
Max. short term temperature (reduced life-time)	70 °C
Max. number discharge cycles	4 cycles per year plus 30 cycles during comissioning
Max. storage time	12 months

4.0 Ah

Battery voltage/cell	1.2 V
Cell type	LA
Case temperature range to ensure 4 years design life	+5 °C to +45 °C
When used with EM powerLED 4W PRO EZ-3	+5 °C to +50 °C
When used with EM powerLED 4W PRO EZ-3 NiMH	70 °C
Max. short term temperature (reduced life-time)	70 °C
Max. number discharge cycles	4 cycles per year plus 30 cycles during comissioning
Max. storage time	12 months

Batteries

Connection method: 4.8 x 0.5 mm spade tag welded to end of cell

For stick packs this connection is accessible after the battery caps have been fitted.



To inhibit inverter operation disconnect the batteries by removing the connector from the battery spade tag.

For further information refer to corresponding battery datasheet.

Storage, installation and commissioning

Relevant information about storage conditions, installation and commissioning are provided in the battery datasheets.

Duration link selection

Duration	Link Position
1 hr	 without jumper
2 hr	 position A
3 hr	 position B

Jumper selection

Module supplied with jumper in 3 hours position (position B).

The position of the link will only be read on first power up. If it is changed afterwards both the battery and mains supply must be disconnected for 10 seconds to enable the EM powerLED EZ-3 to read the new link position on reconnection of the battery and mains. It will lead to a false battery failure indication if the link is changed after installation without this reset.

Further technical data

The EM powerLED has a unique power regulation circuit; this is designed to limit the total power drawn from the battery in the event of using LED's with a forward voltage (Vf) higher than 3.4 V.

In such cases the unit will reduce the LED current in order to maintain an acceptable drain current from the battery and hence meet the required duration time. This feature enables the EM powerLED PRO EZ-3 to have minimum battery count for a given range of LED's.

Testing:**DALI Control**

A DALI command from a suitable control unit can be used to initiate function and duration tests at individually selected times. Status flags are set for report back and data logging of results.

When a DALI bus has not been connected or when a DALI bus is connected but the DALI default DELAY and INTERVAL times have not been re-set by sending appropriate DALI commands, then the EM powerLED PRO EZ-3 will conduct self-tests in accordance with the default times set within the EEPROM. These default times are factory pre-set, in accordance with the DALI standard EN 62386-202, to conduct an automatic function test every 7 days and a duration test every 52 weeks. Since the DELAY time is factory pre-set to Zero, all units are tested at the same time. Test times can be changed with a command over the DALI bus.

The DELAY and INTERVAL time values must be re-set when the emergency system test times are to be scheduled by a DALI control and monitoring system.

Note that once the default values have been set to Zero, tests will only be conducted following a command from the control system. If the DALI bus is disconnected the EM powerLED PRO EZ-3 does not revert to self-testing mode.

Addressing

The EM powerLED PRO EZ-3 includes the new EZ easy addressing system which allows addressing and identification by using the bi-colour LED. Binary address codes given by the LED can be simply converted to the DALI addresses 0 to 63. For single handed addressing using this method it is necessary to send a broadcast ident command every 3 to 9 seconds. During this command the main fluorescent lamp will be switched off and the LED will flash the 6 bit binary address preceded by a 3 second start indication period.

Commissioning

After installation of the luminaire and initial connection of the mains supply and battery supply to the EM powerLED PRO EZ-3 the unit will commence charging the batteries for 20 hours (initial charge). Afterwards the module will conduct a commissioning test for the full duration. The 20 hours recharge occurs also if a new battery is connected or the module exits the rest mode condition. The following automatic commissioning duration test is only performed when a battery is replaced and fully charged (after 20 hrs) and the interval time is not set to zero, otherwise the system is expected to perform the testing.

Functional test

The time of day and frequency of the 5 seconds function test can be set by the DALI controller. The default setting is a 5 seconds test on a weekly basis.

Duration test

The time of day and frequency of the duration test can be set by the DALI controller. The default setting is a duration test conducted every 52 weeks.

Prolong time

Prolong time can be set by the DALI controller. This is the delay time between return of the mains supply and the end of the emergency operation. The default prolong time is set as 0 minutes as specified within the DALI standard.

Indicator LED will stay off for the duration of the prolong time.

Rest Mode / Inhibit Mode

Emergency operation is automatically started when the mains supply is switched off. If the Rest Mode is activated, the discharging of the battery will be minimized by switching off the LED output. If the Inhibit Mode has been activated before the mains supply is switched off, Rest Mode will be automatically switched on if the mains supply is switched off within 15 minutes. Rest Mode and Inhibit Mode can be initiated by the DALI controller. The REST command has to be sent after the mains supply has been disconnected and whilst the EM powerLED PRO is in emergency operation. The INHIBIT command has to be sent while the EM powerLED PRO is supplied by mains.

After a mains reset the EM powerLED PRO exits the Rest Mode. Rest Mode and Inhibit Mode can both be disabled by sending the RE-LIGHT/RESET INHIBIT command.

Test switch

An optional test switch can be wired to each EM powerLED PRO EZ-3. This can be used to initiate a 5 seconds function test by a short press < 1 second.

DALI Controller

DALI controllers and hardware/software solutions are available from Tridonic. Please refer to the Lighting controls section.

Life-time

Average life-time 50,000 hours under rated conditions with a failure rate of less than 10%. Average failure rate of 0.2% per 1000 operating hours.

Insulation and electric strength testing of luminaires

Electronic LED Drivers can be damaged by high voltage. This has to be considered during the routine testing of the luminaires in production.

According to IEC 60598-1 Annex Q (informative only!) or ENEC 303-Annex A, each luminaire should be submitted to an insulation test with 500 V_{DC} for 1 second. This test voltage should be connected between the interconnected phase and neutral terminals and the earth terminal. The insulation resistance must be at least 2 MΩ.

As an alternative, IEC 60598-1 Annex Q describes a test of the electrical strength with 1,500 V_{AC} (or 1,414 x 1,500 V_{DC}). To avoid damage to the electronic devices this test must not be conducted.

Status indication

System status is indicated by a bi-colour LED and by a DALI status flag.

LED indication	Status	Kommentar
Permanent green	System OK	AC mode
Fast flashing green (0,1 sec on – 0,1 sec off)	Function test underway	
Slow flashing green (1 sec on – 1 sec off)	Duration test underway	
Red LED on	Load failure	Open circuit / Short circuit / LED failure ①
Slow flashing red (1 sec on – 1 sec off)	Battery failure	Battery failed the duration test or function / Battery is defect / Incorrect battery voltage
Fast flashing red (0,1 sec on – 0,1 sec off)	Charging failure	Incorrect charging current
Double pulsing green	Inhibit mode	Switching into inhibit mode via controller
Binary transmission of address via green/red LED	Address identification	During address identification mode
Green and red off	DC mode	Battery operation (emergency mode)

① If the EM powerLED is operated in non-maintained mode and an LED fault is detected, the red indicator LED will be illuminated and the output will be stopped. The unswitched mains supply must be switched off before the LED is changed in order that the new LED can be detected. A function or duration test will not reset the fault indication.

Mechanical details

Case manufactured from polycarbonate.

Glow-wire test according to EN 61347-1 with increased temperature of 850 °C passed.

LED bi-colour status indicator

- Green / red
- Mounting hole 6.5 mm diameter, 1 – 1.6 mm thickness
- Lead length 1,000 mm
- Insulation rating: 90 °C

Test switch

- Mounting hole 7.0 mm diameter
- Lead length 550 mm

Battery leads

- Quantity: 1 red and 1 black
- Length: 1,300 mm
- Wire type: 0.5 mm² solid conductor
- Insulation rating: 90 °C

Battery end termination

Push on 4.8 mm receptacle to suit battery spade fitted with insulating cover

Module end termination

8.0 mm stripped insulation

Two-piece batteries are supplied with a 200 mm lead with 4.8 mm receptacles at each end and insulating covers to connect the separate sticks together.

Recommended fixing details for clip fixing

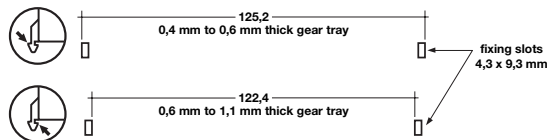

Wiring type and cross section

Wiring

mains (SL, N, L)
LED (LED +, LED -)

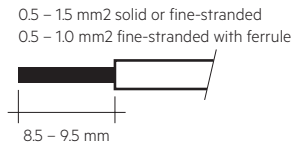

Wiring

batteries (Bat +, Bat -)
test switch (switch)
status indication LED (status K, A)

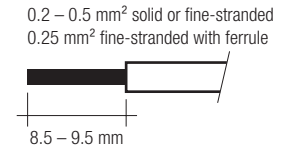

Use one wire for each terminal connector only.

Max. lead insulation diameter

Battery	2.1 mm
Test switch	2.1 mm
Indicator LED	2.1 mm

Maximum lead length

LED	3 m
status indication LED	1 m
batteries	1 m

Release of the wiring

Press down the “push button” and remove the cable from front.

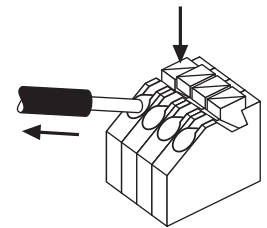

Maximum loading of automatic circuit breakers

Automatic circuit breaker type	B10	C10	B13	C13	B16	C16	B20	C20	Inrush current	
Installation Ø	15 mm ²	15 mm ²	15 mm ²	15 mm ²	25 mm ²	25 mm ²	25 mm ²	25 mm ²	I_{max}	Time
EM powerLED 4 W PRO EZ-3	90	180	130	260	130	260	130	260	10 A	120 µs
EM powerLED 4 W PRO EZ-3 NiMH	90	180	130	260	130	260	130	260	10 A	120 µs

Insulation matrix

	Mains	Switched Live	Battery, LED, Test switch, Indicator LED	DALI
Mains	–	•	••	•
Switched Live	•	–	••	•
Battery, LED, Test switch, Indicator LED	••	••	–	•
DALI	•	•	•	–

• Represents basic insulation

•• Represents double or reinforced insulation

Wiring diagrams

Wiring diagram for one LED or two LED in series

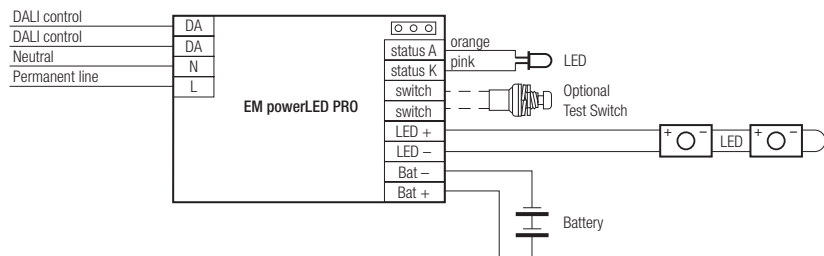

Wiring diagram for multiple LED (3–12) in parallel

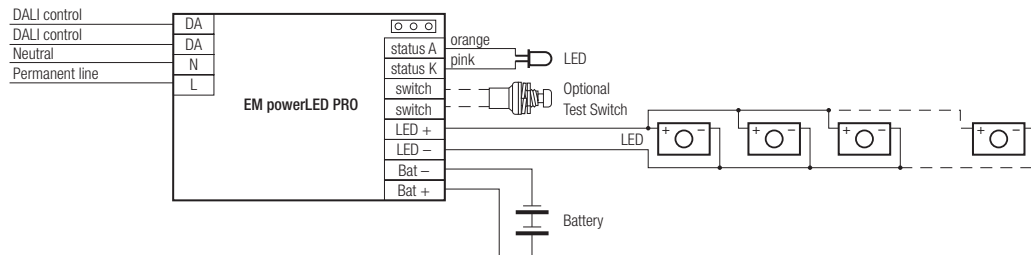

Take care that the LED is connected with the right polarity. LED that are connected to the EM powerLED PRO EZ-3 devices should have a reverse polarity protection device such as a schottky diodes fitted, otherwise irreversible damage could occur if the LED is connected in reverse polarity. Any protection device must be capable of handling in excess of 1,000 mA.

Note: Please ensure that at the terminal of the EM powerLED module the battery negative is not connected to the negative of the LED load.

Manually tested emergency lighting with combined LED modules for general and emergency lighting (e.g. STARK QLE CLASSIC EM, STARK LLE 24-280-1250 EM, STARK CLE CLASSIC EM, STARK SLE CLASSIC EM):

Due to the fact that independent circuits are used for general and emergency lighting it is important that the normal supply of the mains LED Driver is switched off together with the permanent emergency supply prior to checking the operation of the emergency LEDs.

If this is not done then it may not be possible to see that the emergency LEDs are operating.

Use a circuit similar to that shown next.

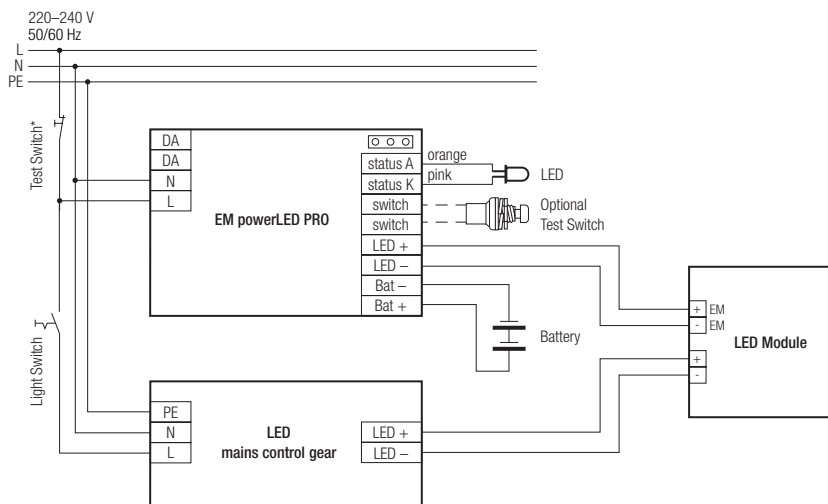

* Use 230 V Test switch

Wiring instructions

- The EM powerLED terminals, battery, indicator LED and test switch terminals are classified as SELV. Keep the wiring of the DALI and the input terminals separated from the wiring of the SELV terminals or consider special wiring (double insulation, 6 mm creepage and clearance) when these connections should be kept SELV.
- The output to the LED is DC but has high frequency content at 125 kHz, which should be considered for good EMC compliance.
- EM powerLED leads should be separated from the mains and DALI connections and wiring for good EMC performance. With some luminaires it may be necessary to add a ferrite bead inductor to obtain satisfactory EMC performance.
- Maximum lead length on the EM powerLED terminals is 3 m. For a good EMC performance keep the LED wiring as short as possible.
- The secondary wires (LED module) should be routed in parallel to ensure good EMC performance.
- Maximum lead length for the test switch and Indicator LED connection is 1 m. The test switch and Indicator LED wiring should be separated from the EM powerLED leads to prevent noise coupling.
- Battery leads are specified with 0.5 mm² cross section and a length of < 1.3 m.
- DALI terminals are mains proof.
- To avoid the damage of the control gear, the wiring must be protected against short circuits to earth (sharp edged metal parts, metal cable clips, louver, etc.).

Maximum number of switching cycles

All LED Drivers are tested with 50,000 switching cycles.
The actually achieved number of switching cycles is significantly higher.

Additional information

Additional technical information at www.tridonic.com → Technical Data

Guarantee conditions at www.tridonic.com → Services

Life-time declarations are informative and represent no warranty claim.
No warranty if device was opened.