

## EOS (Electrical Over Stress) / ESD (Electrostatic Discharge) guidelines

An EOS/ESD-safe workstation (see Fig. 1 and Fig. 2) prevents damage or potential damage to sensitive electronic components caused by voltage peaks and static discharges.



An earth connection must be provided to divert static discharges, otherwise the discharges may pass to the components. Workplaces with conductive or anti-static surfaces must be used. The employee must also be connected to earth by an armband to divert any static charges caused by clothing.

The connection between the employee to earth must be via resistors connected in series so that the employee is protected in the event of a malfunction. This is also necessary to ensure a soft discharge and prevent arc-overs.

The following table indicates permitted values for resistors and the discharge times for safe electrostatic working.

Discharge for the employee via	Maximum permitted resistance	Maximum permitted discharge time
Floor mat to earth	1,000 MΩ	Less than 1 second
Desk mat to earth zur Erde	1,000 MΩ	Less than 1 second
Armband to earth	100 MΩ	Less than 0.1 second

The workplace must be free of any material that contains

- plastics
- polystyrene or
- unsuitable ESD protective cases or folders.



EOS/ESD workplaces must be inspected regularly to ensure they provide adequate protection. Tools and other work materials must be maintained and checked regularly for correct operation.

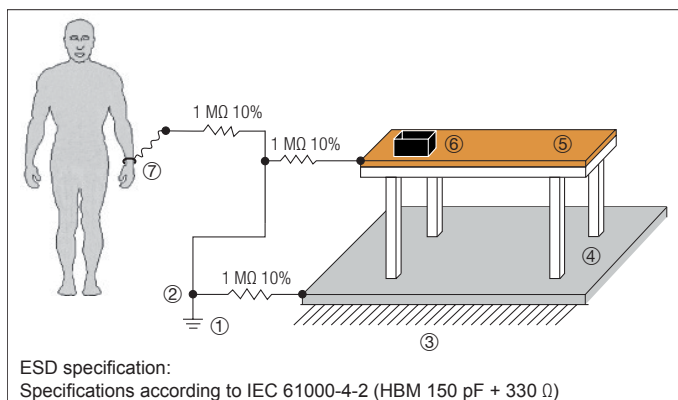

Fig. 1

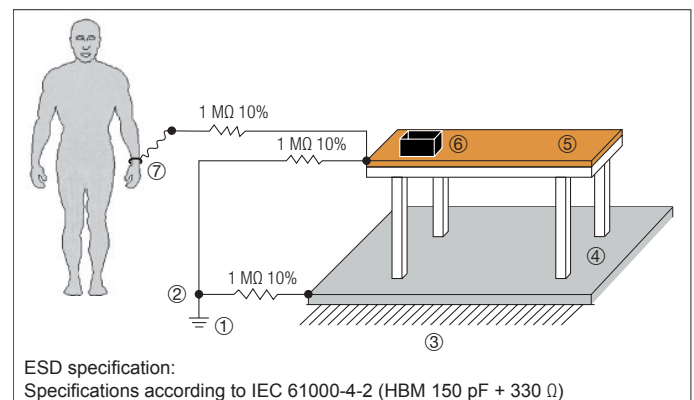

Fig. 2

- ① Earth
- ② Common earthing point
- ③ Floor or building
- ④ EOS-protected flooring or mat
- ⑤ EOS-protected desk surface
- ⑥ EOS-protected bowls, containers, etc.
- ⑦ Personal armband