



PCA T8 EXCEL one4all Ip x!tec II, 18 – 58 W
T8 fluorescent lamps

Product description

- Processor-controlled ballast with x!tec II inside
- CELMA energy class A1 BAT[®]
- Noise-free precise control via DSI signal, switchDIM, corridorFUNCTION or DALI
- Nominal lifetime up to 100,000 h (at ta 50 °C with a failure rate of max. 0,2 % per 1.000 h)
- OEM-specific reserved memory areas
- Extended DALI commands
- 5-year guarantee

Interfaces

- DALI
- DSI
- switchDIM (with memory function + selectable dimming rate)
- corridorFUNCTION (3 preprogrammed profiles + individually programmable)
- Integrated SMART-Interface for operation with all SMART-Sensors and SMART-Plugs

Functions

- Intelligent Temperature Guard (overtemperature protection)
- Intelligent Voltage Guard (overvoltage indication and undervoltage shutdown)
- Optimum filament heating in any dimmer setting
- Disconnection of filament heating from a dimming level of approx. 90 % for maximum energy efficiency (SMART-Heating Concept)
- Fade rates between 100 ms and 90 s (min-max.)
- corridorFUNCTION with daylight control
- Automatically triggered emergency lighting value in DC mode 15 %, adjustable between 1 – 100 %
- For emergency lighting systems as per EN 50172
- Automatic start after replacement of defective lamps
- Automatic shutdown if the lamp is faulty
- Dimming possible in DC mode

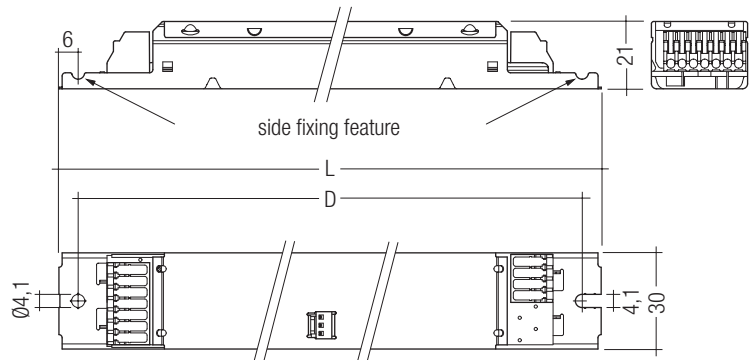
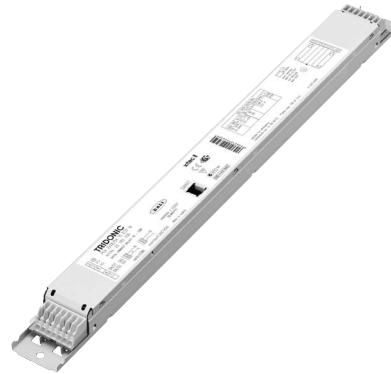

Technical data

AC voltage range	198 – 264 V
DC voltage range	176 – 280 V (lamp start \geq 198 V DC)
Overvoltage protection	320 V AC, 1 h
Typ. power input on standby	< 0.2 W
Protective hot restart	0.5 s for AC / 0.2 s for DC
Dimming range	1 – 100 %
Lamp start possible from	1 %
Operating frequency	~40 – 130 kHz
Height	21 mm

Ordering data

Type	Article number
For luminaires with 1 lamp	
PCA 1x18 T8 EXCEL one4all Ip x!tec II	22185239
PCA 1x36 T8 EXCEL one4all Ip x!tec II	in preparation
PCA 1x58 T8 EXCEL one4all Ip x!tec II	in preparation
For luminaires with 2 lamps	
PCA 2x18 T8 EXCEL one4all Ip x!tec II	22185242
PCA 2x36 T8 EXCEL one4all Ip x!tec II	in preparation
PCA 2x58 T8 EXCEL one4all Ip x!tec II	in preparation

Packaging 360 mm casing: 10 pieces/carton, 760 pieces/pallet

Packaging 425 mm casing: 10 pieces/carton, 640 pieces/pallet



Standards, page 3

Wiring diagrams and installation examples, page 8

Specific technical data

Lamp wattage	Lamp type	Type	Article number	Length L	Hole spacing D	Weight	Circuit power [®]	Lamp wattage [®]	EI	Current at 230 V / 50 Hz [®]	λ at 50 Hz / 230 V	tc point	Ambient temperature ta [®]
For luminaires with 1 lamp													
1 x 18 W	T8	PCA 1x18 T8 EXCEL one4all Ip x:tec II	22185239	360 mm	350 mm	0.25 kg	18.5 W	16.5 W	A1 BAT	0.08 A	0.96	80 °C	-25 ... 70 °C
1 x 36 W	T8	PCA 1x36 T8 EXCEL one4all Ip x:tec II	in preparation	360 mm	350 mm	0.25 kg	tbd	tbd	A1 BAT	tbd	tbd	tbd	tbd
1 x 58 W	T8	PCA 1x58 T8 EXCEL one4all Ip x:tec II	in preparation	360 mm	350 mm	0.25 kg	tbd	tbd	A1 BAT	tbd	tbd	tbd	tbd
For luminaires with 2 lamps													
2 x 18 W	T8	PCA 2x18 T8 EXCEL one4all Ip x:tec II	22185242	360 mm	350 mm	0.25 kg	37.5 W	32.5 W	A1 BAT	0.16 A	0.98	75 °C	-25 ... 60 °C
2 x 36 W	TC-L	PCA 2x36 T8 EXCEL one4all Ip x:tec II	in preparation	360 mm	350 mm	0.25 kg	tbd	tbd	A1 BAT	tbd	tbd	tbd	tbd
2 x 58 W	T8	PCA 2x58 T8 EXCEL one4all Ip x:tec II	in preparation	425 mm	415 mm	0.35 kg	tbd	tbd	A1 BAT	tbd	tbd	tbd	tbd

[®] According to the EU directives on ecodesign requirements (EC) No. 245/2009 and (EC) No. 347/2010.

[®] Valid at 100 % dimming level.

[®] +10 °C to ta max: unrestricted dimming. -25 °C to +10 °C: unrestricted dimming from 100 % to 30 %.
-25 °C to +10 °C, dimming below 30 %: malfunction possible but no damage to ECG. This applies to AC and DC operation.

Standards

EN 55015
EN 55022
EN 60929
EN 61000-3-2
EN 61347-2-3
EN 61547
Suitable for emergency installations according to
EN 50172
CISPR 15
CISPR 22
IEC 60929
IEC 61000-3-2
IEC 61347-2-3
IEC 61547
IEC 62386

Lamp starting characteristics

Warm start
Starting time 0.5 s with AC
Starting time 0.2 s with DC
Start at any dimming level

AC operation

Mains voltage
220–240 V 50/60 Hz
198–264 V 50/60 Hz including safety
tolerance ($\pm 10\%$)
198–254 V 50/60 Hz including performance
tolerance (+6 % / -8 %)

DC operation

220–240 V 0 Hz
198–254 V 0 Hz certain lamp start
176–280 V 0 Hz operating range
Use in emergency lighting installations according to
EN 50172 or for emergency luminaires according
to EN 61347-2-3 appendix J.

Mains current for defective or missing lamps at DC
operation < 35 mA.

Light output level in DC operation

Programmable from 1 % to 100 %
Programming by extended DSI or DALI signal (16 bit).
Default value is 15 %
In DC operation dimming mode can be activated.

Emergency units

The "PCA T8 EXCEL one4all Ip xitec II" ballasts are
compatible with all emergency units from Tridonic.
See the table in the data sheet. Also all "5-pole"
emergency units can be used. When used with other
emergency units tests are necessary.

Temperature range

Unlimited dimming range from 10 °C to ta max.
-25 °C to 10 °C: dimming operation from 100 %
to 30 %. If dimm level goes below 30 % malfunction
possible, but no electronic ballast damage.
This applies to AC and DC operation.

Mains currents in DC operation (at 15 % light output)

Type	Lamp type	Wattage	Mains current at	
			$U_n = 220 V_{DC}$	$U_n = 275 V_{DC}$
PCA 1x18 T8 EXCEL one4all Ip xitec II	T8	1x18 W	0.09 A	0.07 A
PCA 1x36 T8 EXCEL one4all Ip xitec II	T8	1x36 W	tbd	tbd
PCA 1x58 T8 EXCEL one4all Ip xitec II	T8	1x58 W	tbd	tbd
PCA 2x18 T8 EXCEL one4all Ip xitec II	T8	2x18 W	0.17 A	0.14 A
PCA 2x36 T8 EXCEL one4all Ip xitec II	T8	2x36 W	tbd	tbd
PCA 2x58 T8 EXCEL one4all Ip xitec II	T8	2x58 W	tbd	tbd

Ballast lumen factor AC operation (AC-BLF) EN 60929 8.1

Type	Lamp type	Wattage	AC-BLF at $U = 230 V_{AC}$
PCA 1x18 T8 EXCEL one4all Ip xitec II	T8	1x18 W	0.99
PCA 1x36 T8 EXCEL one4all Ip xitec II	T8	1x36 W	tbd
PCA 1x58 T8 EXCEL one4all Ip xitec II	T8	1x58 W	tbd
PCA 2x18 T8 EXCEL one4all Ip xitec II	T8	2x18 W	0.99
PCA 2x36 T8 EXCEL one4all Ip xitec II	T8	2x36 W	tbd
PCA 2x58 T8 EXCEL one4all Ip xitec II	T8	2x58 W	tbd

The ballast lumen factor for AC operation (AC-BLF) does not alter from $U_n = 198 V_{AC}$ to $U_n = 254 V_{AC}$.
The ballast lumen factor for DC operation (DC-BLF) on the basis of an automatic power reduction of the ballasts
(default value is 15 %) will be smaller than AC. It does not alter in the DC operating range (198–264 V DC).

Dimming

Dimming curve is adapted to the eye sensitiveness.

Dimming range 1 % to 100 %

Digital control with:

- DSI signal: 8 bit Manchester Code
Speed 1 % to 100 % in 1.4 s
- DALI signal: 16 bit Manchester Code
Maximum speed 1 % to 100 % in 550 ms (adjustable between 100 ms and 90 s)
Programmable parameter:
Minimum dimming level
Maximum dimming level
Default minimum = 1 %
Default maximum = 100 %

Control input (DA/D1, DA/D2)

Digital DALI/DSI signal or a push-to-make switch (switchDIM) or a motion detector (corridorFUNCTION) can be wired on the same terminals (DA/D1 and DA/D2).

Digital signal DALI/DSI

The control input is non-polar and protected against accidental connection with a mains voltage up to 264 V. The control signal is not SELV. Control cable has to be installed in accordance to the requirements of low voltage installations.

Different functions depending on each module.

SMART interface

An additional interface for the direct connection of the SMART-Sensoren or SMART-Plugs.

For precise instructions relating to the available sensors and plugs and for a description of how they work in connection with the PCA devices please see the separate documentation for PCA xitec II.

The equipment must be installed in accordance with the relevant directives on low voltage. Ensure that power to the ballast is switched off before connecting or disconnecting the sensors and plugs.

switchDIM

Integrated switchDIM function allows a direct connection of a push to make switch for dimming and switching.

Brief push (< 0.6 s) switches ballast ON and OFF. The ballasts switch-ON at light level set at switch-OFF. After switch ON the last settet dimming level will be activated again.

When the push to make switch is held, PCA ballasts are dimmed. After repush the PCA is dimmed in the opposite direction.

The switchDIM fade time is set to 3 s from min. to max. in the factory settings. With a 20 s push to the push to make switch this fade time can be changed to 6 s. In this instance the switchDIM application will be synchronized to 50 % light level after 10 s and after 20 s the light level rises to 100 % with the new fade time.

At every synchronisation (10 s keystroke) the device will reset to 3 s (factory setting)

In installations with PCAs with different dimming levels or opposite dimming directions (e.g. after a system extension), all PCAs can be synchronized to 50 % dimming level by a 10 s push.

Use of push to make switch with indicator lamp is not permitted.

switchDIM and corridorFUNCTION are very simple tools for controlling ballasts with conventional momentary-action switches or motion sensors. To ensure correct operation a sinusoidal mains voltage with a frequency

**Dimming characteristics
PCA T8 EXCEL one4all Ip xitec II**

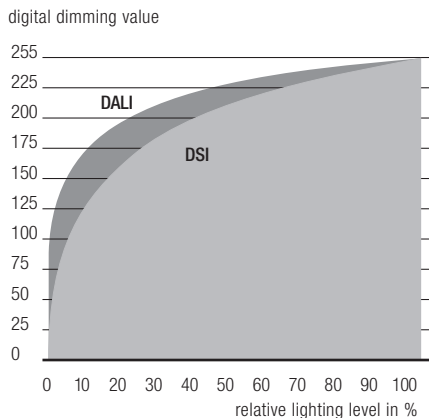

Dimming characteristics as seen by the human eye

**Energy saving
PCA T8 EXCEL one4all Ip xitec II**

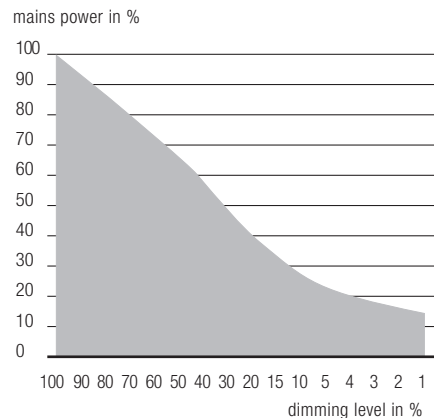

of 50 Hz or 60 Hz is required at the control input. Special attention must be paid to achieving clear zero crossings. Serious mains faults may impair the operation of switchDIM and corridorFUNCTION.

corridorFUNCTION

To activate the corridorFUNCTION a voltage of 230 V simply has to be applied for five minutes at switchDIM connection. The unit will then switch automatically to the corridorFUNCTION.

Note: If the corridorFUNCTION is wrongly activated in a switchDIM system (for example a switch is used instead of pushbutton), there is the option of installing a pushbutton and deactivating the corridorFUNCTION mode by five short pushes of the button within three seconds.

The corridorFUNCTION offers the added benefit of a second and third preprogrammed profile, which can be activated by the SMART-Plugs.

It is also possible to combine the corridorFUNCTION with the SMART-Sensor 5D 19f light sensor.

Application and functionality of profiles see user manual of the corridorFUNCTION.

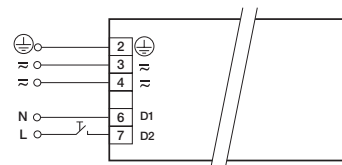

switchDIM PCA T8 EXCEL one4all Ip xitec II

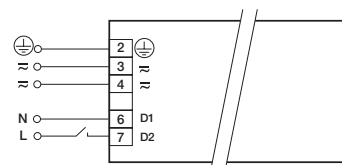

corridorFUNCTION PCA T8 EXCEL one4all Ip xitec II

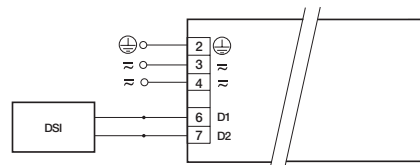

DSI PCA T8 EXCEL one4all Ip xitec II

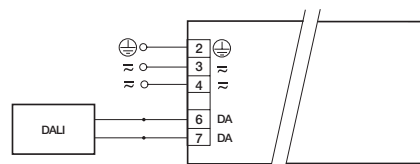

DALI PCA T8 EXCEL one4all Ip xitec II

Loading of automatic circuit breakers (Limitation via inrush current)

Automatic circuit breaker type	C10		C13		C16		C20		B10		B13		B16		B20		Inrush current (1.5 mm ²)		Inrush current (2.5 mm ²)		
	Installation Ø	1.5 mm ²	1.5 mm ²	1.5 mm ²	2.5 mm ²	1.5 mm ²	1.5 mm ²	1.5 mm ²	2.5 mm ²	1.5 mm ²	1.5 mm ²	1.5 mm ²	2.5 mm ²	I _{max}	time	I _{max}	time	I _{max}	time	I _{max}	time
PCA 1x18 T8 EXCEL one4all Ip xitec II	50	82	161	201	25	41	120	107	19.3 A	166 µs	19.7 A	165 µs									
PCA 1x36 T8 EXCEL one4all Ip xitec II	tbd	tbd	tbd	tbd	tbd	tbd	tbd	tbd	tbd	tbd	tbd	tbd	tbd	tbd	tbd	tbd	tbd	tbd	tbd	tbd	tbd
PCA 1x58 T8 EXCEL one4all Ip xitec II	tbd	tbd	tbd	tbd	tbd	tbd	tbd	tbd	tbd	tbd	tbd	tbd	tbd	tbd	tbd	tbd	tbd	tbd	tbd	tbd	tbd
PCA 2x180 T8 EXCEL one4all Ip xitec II	34	50	76	86	17	25	38	43	20.3 A	204 µs	23.3 A	184 µs									
PCA 2x36 T8 EXCEL one4all Ip xitec II	tbd	tbd	tbd	tbd	tbd	tbd	tbd	tbd	tbd	tbd	tbd	tbd	tbd	tbd	tbd	tbd	tbd	tbd	tbd	tbd	tbd
PCA 2x58 T8 EXCEL one4all Ip xitec II	tbd	tbd	tbd	tbd	tbd	tbd	tbd	tbd	tbd	tbd	tbd	tbd	tbd	tbd	tbd	tbd	tbd	tbd	tbd	tbd	tbd

Continuous operation: to calculate the protective safety switch see main current, page 2

Intelligent Voltage Guard

Intelligent Voltage Guard is the name of the electronic monitor from Tridonic. This innovative feature of the PCA family of control gear from Tridonic immediately shows if the mains voltage rises above certain thresholds. Measures can then be taken quickly to prevent damage to the control gear.

- If the mains voltage rises above approx. 318 V_{rms} (voltage depends on the ballast type), the lamp starts flashing on and off.
- To avoid a damage of the device the mains supply has to be switched off at this signal.

Intelligent Temperature Guard

The intelligent temperature guard protects the PCA T8 EXCEL one4all Ip xitec II from thermal over-heating by reducing the output power or switching off in case of operation above the thermal limits of the luminaire or ballast. Depending on the luminaire design, the ITG operates at about 5 to 10 °C above to temperature.

Harmonic distortion in the mains supply (at 230V/50Hz)

Type	Lamp type	Wattage	THD	3	5	7	9	11
PCA 1x18 T8 EXCEL one4all Ip xitec II	T8	1x18 W	9	5	2	1	1	1
PCA 1x36 T8 EXCEL one4all Ip xitec II	T8	1x36 W	tbd	tbd	tbd	tbd	tbd	tbd
PCA 1x58 T8 EXCEL one4all Ip xitec II	T8	1x58 W	tbd	tbd	tbd	tbd	tbd	tbd
PCA 2x18 T8 EXCEL one4all Ip xitec II	T8	2x18 W	8	5	2	1	1	1
PCA 2x36 T8 EXCEL one4all Ip xitec II	T8	2x36 W	tbd	tbd	tbd	tbd	tbd	tbd
PCA 2x58 T8 EXCEL one4all Ip xitec II	T8	2x58 W	tbd	tbd	tbd	tbd	tbd	tbd

Operating voltage

Type	Lamp type	Wattage	U _{out}
PCA 1x18 T8 EXCEL one4all Ip xitec II	T8	1x18 W	430 V
PCA 1x36 T8 EXCEL one4all Ip xitec II	T8	1x36 W	430 V
PCA 1x58 T8 EXCEL one4all Ip xitec II	T8	1x58 W	430 V
PCA 2x18 T8 EXCEL one4all Ip xitec II	T8	2x18 W	430 V
PCA 2x36 T8 EXCEL one4all Ip xitec II	T8	2x36 W	430 V
PCA 2x58 T8 EXCEL one4all Ip xitec II	T8	2x58 W	430 V

Humidity: 5 % up to max. 85 %, not condensed (max. 56 days/year at 85 %)

Storage temperature: -40 °C up to max. +80 °C

The devices have to be within the specified temperature range (ta) before they can be operated.

Expected lifetime

Type	Lamp type	Wattage	ta = 40 °C			ta = 50 °C			ta = 60 °C			
			tc	Lifetime	tc	Lifetime	tc	Lifetime	tc	Lifetime	tc	Lifetime
PCA 1x18 T8 EXCEL one4all Ip xitec II	T8	1 x 18 W	50 °C	60 °C	70 °C	≥ 100,000 h	≥ 100,000 h	≥ 100,000 h				
			tbd	tbd	tbd							
PCA 1x36 T8 EXCEL one4all Ip xitec II	T8	1 x 36 W	tbd	tbd	tbd							
			tbd	tbd	tbd							
PCA 1x58 T8 EXCEL one4all Ip xitec II	T8	1 x 58 W	tbd	tbd	tbd							
			tbd	tbd	tbd							
PCA 2x18 T8 EXCEL one4all Ip xitec II	T8	2 x 18 W	60 °C	70 °C	80 °C	≥ 100,000 h	≥ 100,000 h	≥ 50,000 h				
			tbd	tbd	tbd							
PCA 2x36 T8 EXCEL one4all Ip xitec II	T8	2 x 36 W	tbd	tbd	tbd							
			tbd	tbd	tbd							
PCA 2x58 T8 EXCEL one4all Ip xitec II	T8	2 x 58 W	tbd	tbd	tbd							
			tbd	tbd	tbd							

x = not permitted

Installation instructions

Wiring type and cross section

The wiring can be solid cable with a cross section of 0.5 to 0.75 mm² for push terminal and 0.5 mm² for IDC terminal. For the push-wire connection you have to strip the insulation (8–9 mm).

wire preparation:
0.5 – 0.75 mm²

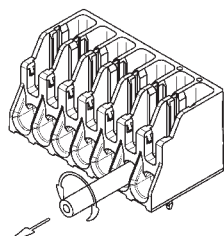
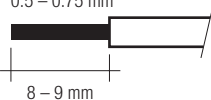

Loosen wire through
twisting and pulling

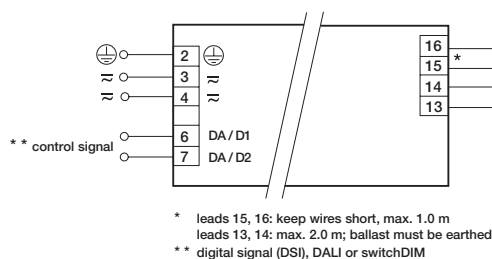

PCA T8 EXCEL one4all Ip xitec II 1x14-80 W

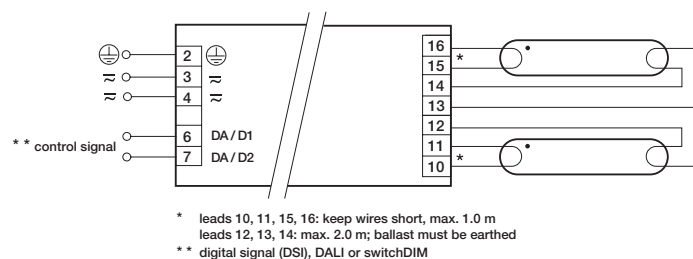

PCA T8 EXCEL one4all Ip xitec II 2x14-80 W

Dimmable ballasts from Tridonic have to be earthed.

Wiring advice

The lead length is dependent on the capacitance of the cable.

Ballast	Terminal	Maximum capacitance allowed			
		Cold	Hot	Cold	Hot
PCA 1xx T8 EXCEL one4all Ip xitec II		13, 14	15, 16	200 pF	100 pF
PCA 2xx T8 EXCEL one4all Ip xitec II		12, 13, 14	10, 11, 15, 16	200 pF	100 pF

With standard solid wire 0.5/0.75 mm² the capacitance of the lead is 30–80 pF/m.

This value is influenced by the way the wiring is made.

Lamp connection should be made with symmetrical wiring.

Hot leads (10, 11, 15, 16) and cold leads (12, 13, 14) should be separated as much as possible.

When using two or more dimmable ballasts in one luminaire with separate dimming controls, the lamp leads must be kept separate.

Dimmable ballasts from Tridonic have to be earthed.

RFI

- Connection to the lamps of the hot leads must be kept as short as possible
- Mains leads should be kept apart from lamp leads (ideally 5–10 cm distance)
- Do not run mains leads adjacent to the electronic ballast
- Twist the lamp leads
- Keep the distance of lamp leads from the metal work as large as possible
- Mains wiring to be twisted when through wiring
- Keep the mains leads inside the luminaire as short as possible

General advise

Electronic ballasts are virtually noise free.

Magnetic fields generated during the ignition cycle can cause some background noise but only for a few milliseconds.

Operation on DC voltage

Our ballasts are constructed to operate DC voltage and pulsed DC voltage.

To operate ballasts with pulsed DC voltage the polarity is absolute mandatory.

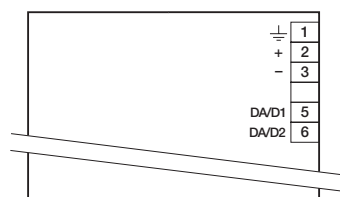

① For further technical information please visit www.tridonic.com

Isolation and electric strength testing of luminaires

Electronic devices can be damaged by high voltage. This has to be considered during the routine testing of the luminaires in production.

According to IEC 60598-1 Annex Q (informative only!) or ENEC 303-Annex A, each luminaire should be submitted to an isolation test with 500 Vdc for 1 second. This test voltage should be connected between the interconnected phase and neutral terminals and the earth terminal.

The isolation resistance must be at least 2 MΩ.

As an alternative, IEC 60598-1 Annex Q describes a test of the electrical strength with 1500 VAC (or 1.414 x 1500 Vdc). To avoid damage to the electronic devices this test must not be conducted.

Glow-wire test according to EN 60598-1

650 °C, 750 °C and 850 °C passed

Programming

With appropriate software and a USB interface different functions can be activated and various parameters can be configured in the new PCA TC EXCEL one4all Ip xitec II. All that is needed is a DALI-USB and the software.

Master Configurator

For programming the corridorFUNCTION, device configuration (fade time, ePowerOnLevel, etc.) DC level, compatibility settings, and startup date and for resetting.

Maximum amount of ballast see DALI/DSI specification.

